

MODELS SE80PLH SE90PLH SE110PLH SE150PLH

Ultra Silent, High Performance, Attractive Design Grille

Description

- Ventilating fan should be ceiling or wall mounted and capable of exhausting air quietly and efficiently. The SE series is HVI and ENERGY STAR certified.
- It comes with a capacitor start motor which is known for its high efficiency and long lasting reliability. It holds an ETL evaluation and conforms to UL and cUL safety standards.
- This fan has a unique plug and play concept that allows you to add accessories such as motion sensor, humidistat, light, or even speed/controller without changing the fan.

Housing

- Made of rugged 26 GA galvanized steel
- Detachable 6 inch polymeric resin collar which includes a light weight built in back draft damper.
- Double hanger bar mounting brackets that are adjustable up to 24 inch span allows for ideal positioning.

Motor/Blower

- Plug in permanently lubricated motor- Engineered for continuous operation.
- The motor is energy efficient and surpasses the minimum ENERGY STAR requirements for continuous duty operation.
- Power rating should be 120 volts and 60 Hz.
- Fan shall be ETL and cETL listed for tub/shower enclosure when used with a GFCI branch circuit.
- Motor comes with a built in overload disconnect for safety and longer motor life.
- Our Premium series operates at lower RPM's to give you quieter operation.

Grille

- The Premium grille is low profile that has elegance and still able to maintain its simplicity.
- Made of a rugged polymeric resin that's known for its long life durability.
- Comes with torsion spring clips that helps mount grille evenly.
- Energy efficient lighting - uses 26W (max.) high efficiency , GU 24 based, fluorescent lamps and 4W night light.

Typical specification

- Ceiling ventilator shall have corrosion resistance galvanized steel housing with 4 point mounting capability.
- It shall be ducted to a roof vent or wall cap using 6 inch round pipe.
- Blower assembly shall be removable, have a centrifugal type blower wheel and a permanently lubricated motor designed for continuous operation.
- The humidity-sensing fan uses a sophisticated humidity sensor that responds to: (a) rapid to moderate (user-adjustable) increases in humidity or (b) humidity above a user-adjustable setpoint (30%-80% relative humidity). The humidity sensor may occasionally tum the fan ON when environmental conditions change. If the fan continuously responds to changing environmental conditions "H"(means "humidity") adjustment may be required. This figure is factory-set for about 80% (Ambient temperature of 25).
- Air and sound delivery shall meet the HVI certified ratings as per the fan curves attached.
- Airzone ventilators come with permanent split capacitor motor which improves efficiency this is why it has qualified to carry the ENERGY STAR label.



Optional
Speed controller
Metal Grille

Reference	QTY.	Remarks	Project:
			Location:
			Architect:
			Engineer:
			Contractor:
			Submitted by:
			Date:

CERTIFICATIONS



Model Number	SE80PLH		SE90PLH		SE110PLH		SE150PLH	
Static Pressure in inches w.g.	0.1	0.25	0.1	0.25	0.1	0.25	0.1	0.25
Air Volume (CFM)	80	69	90	69	110	86	150	123
Noise (sones)	0.4	1.1	0.4	1.1	0.9	1.2	0.5	1.2
Fan Watts	25	25	25	25	32	32	40	40
Duct Diameter	6 in.							
Power Rating (V/Hz)	120/60							

HVI Certified performance based on HVI Procedures 915, 916, and 920.

Other airflow reference performance based on HVI Procedures 915, 916, and 920.

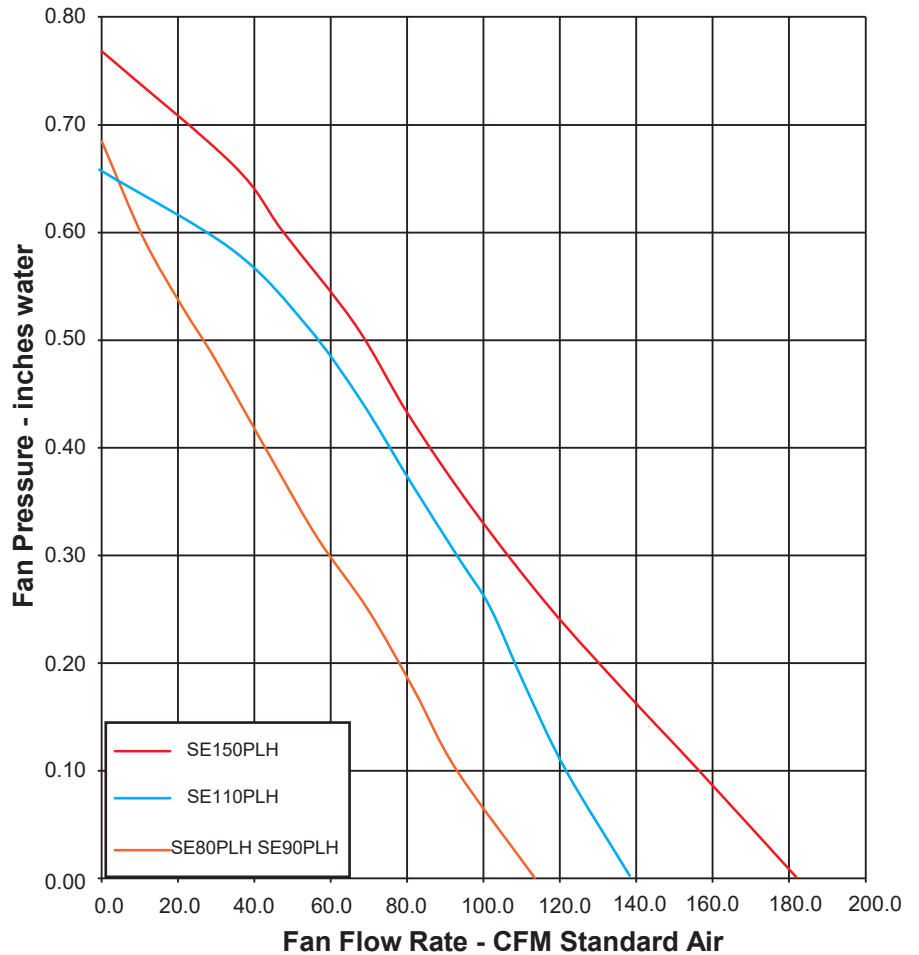
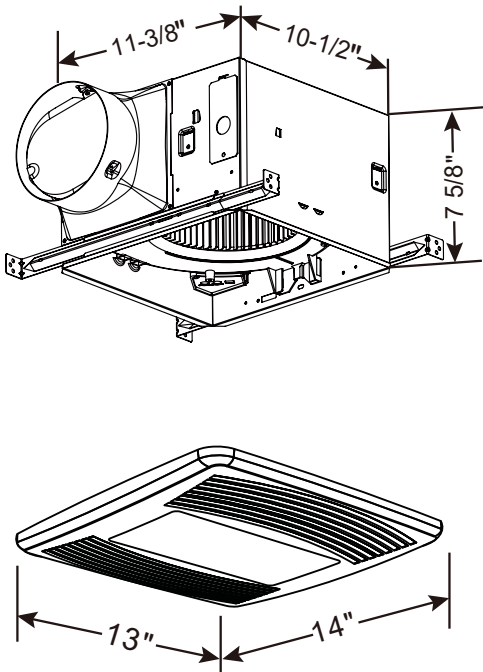

CERTIFICATIONS

